



ShenZhen Fest Technology Co.,ltd

Baoshan Industrial Park, Longhua, Bao'an, Shenzhen, 518113,China

www.efestpower.com TEL:0755-89304183 FAX: 0755-27764602

LI—MN battery Specification

Model/型号：IMR18650

Capacity/容量：2500mAh

Voltage/电压：3.7V

Prepared By/Date 编制/日期	Checked By/Date 审核/日期	Approved By/Date 批准/日期

Amendment Records (修正记录)				
Edition (版本)	Description (记述)	Prepared by (编制)	Approved by (批准)	Date (日期)
A	First Edition			



ShenZhen Fest Technology Co.,ltd

Baoshan Industrial Park, Longhua, Bao'an, Shenzhen, 518113,China

www.efestpower.com TEL:0755-89304183 FAX: 0755-27764602

1 Scope (使用范围)

This specification is applied to the reference battery in this Specification and manufactured by Shenzhen Fest Technology Co.,Ltd.

本规格书适用于本书中所提及的深圳费思特科技有限公司制造的电池。

2 Product Specification (产品技术规格)

Table 1 (表 1)

No. (序号)	Item (项目)	General Parameter (常规参数)		Remark (备注)
1	Rated Capacity (额定容量)	Typical (标称容量)	2500mAh	Standard discharge (0.2C) after standard charge (标准充电后 0.2C 标准放电)
		Minimum (最小容量)	2400mAh	
2	Nominal Voltage (正常电压)	3.7V		Mean Operation Voltage (即工作电压)
3	Voltage at end of Dischargr (放电终止电压)	2.50V		Discharge Cut-off Voltage (放电截止电压)
4	Charging at end of Voltage (充电最高电压)	4.20V		
5	Standard charge (标准充电)	Constant Current 1A, Constant Voltage 4.20V (持续电流: 1A 持续电压: 4.20V)		Charge time: Approx 4.5h (充电时间: 大约 4.5 个小时)
6	Standard discharge (标准放电)	Constant Current 500mA, end Voltage 2.50V (持续电流: 500mA 截止电压 2.50V)		
7	Fast charge (快速充电)	Constant Current: 2000mA Constant voltage: 4.20V		Charge time: Approx 2.5h (充电时间: 大约 2.5 个小时)
8	Fast discharge (快速放电)	Constant current: 20000mA,35000mA		
9	End voltage(cut off)	2.50V		
10	Max charging voltage	4.20V		
11	Operation Temperature Range (工作温度范围)	Charge (充电): 0~45°C		60±25%R.H. Bare Cell (单体电池储存湿度范围)
		Discharge (放电): -20~75°C		
12	Storage Temperature Range (储存温度范围)	Less than 1 year: -20~25°C (小于 1 年: -20~25°C)		60±25%R.H. at the shipment state (出货状态时的湿度范 围)
		Less then 3 months: -20~40°C		



ShenZhen Fest Technology Co.,ltd

Baoshan Industrial Park, Longhua, Bao'an, Shenzhen, 518113,China

www.efestpower.com TEL:0755-89304183 FAX: 0755-27764602

		(小于 3 个月: -20~40℃)	
13	Weight (重量)	50g	FYI
14	Pack Dimension (包装后尺寸)	Height: (h) (高度): 65.0±0.3mm	Initial Dimension (初始尺寸)
		Width: (d) (直径): 18.3±0.3mm	

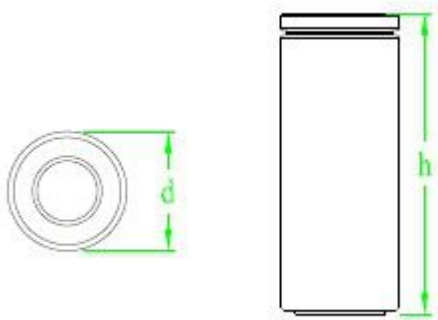

3 Performance And Test Conditions (电池性能及测试条件)

Standard Test Conditions (标准测试条件)

Test should be conducted with new batteries within one week after shipment from our factory and the cell shall not be used for more than five times of charging and discharging before the test. Unless otherwise specified, test and measurement shall be done under temperature of $20 \pm 5^\circ\text{C}$ and relative humidity of 45~48%.if it is judged that the test results are not affected by such conditions, the tests may be conducted at temperature $15\sim 30^\circ\text{C}$ and humidity 25-85%R.H.

测试必须使用出厂时间不超过一个星期的新电池，且未进行过 5 次以上的充放电循环。除非特别说明，否则测试会在温度 $20 \pm 5^\circ\text{C}$ ，相对湿度在 45-85%的条件下进行。如果经鉴定测试结果不受上述条件影响，测试也可以在温度 $15\sim 30^\circ\text{C}$ ，相对湿度在 25-85%RH 的条件下进行。

Measuring Instrument or Apparatus (测量器具及设备)

Dimension Measuring Instrument (尺寸测量器具)

The precision level of the dimension measurement instrument should not be less than 0.01mm.

尺寸测量器具的精度等级应不小于 0.01mm。



ShenZhen Fest Technology Co.,ltd

Baoshan Industrial Park, Longhua, Bao'an, Shenzhen, 518113,China

www.efestpower.com TEL:0755-89304183 FAX: 0755-27764602

Voltager (伏特计)

As standard class specified in the national standard or more sensitive class, the inner impedance should not more than $10k \Omega/V$.

按照国家标准指定规格等级或采用灵敏度更高的, 测量电压时内阻不应小于 $10k \Omega/V$ 。

Ammeter (安培计)

As standard class specified in the national standard or more sensitive class.Total external resistance including ammeter and wire should be less than 0.01Ω .

按照国家标准指定规格等级或采用灵敏度更高的, 包括电流表及电线在内的总外阻应小 0.01Ω 。

Impedance Meter (电阻计)

Impedance shall be measured by AC impedance method(1kHz LCR meter)

内阻测试仪测量原理应为交流阻抗法 (1kHz LCR)。

Standard Charge/Discharge (标准充放电)

Standard charge: Test procedure and its criteria are referred as follows:

标准充电: 测试过程及标准如下:

Charging shall consist of standard charging at a 0.2 C constant current rate until the cell reaches 4.20V. The cell shall then be charged at constant voltage of 4.20 volts while tapreing the charge current Charging shall be terminated when the charging current has tapreed to 0.02 C. Charge time: Approx 6.0h, The cell shall demonstrate no permanent degradation when charged between $0^{\circ}C$ and $45^{\circ}C$.

电池先 0.2C 恒流充至 4.20V, 当充电电流逐渐减小时, 再以 4.20V 恒压充至电流减小到 0.02 C, 充电时间大约为 6 个小时。在 $0^{\circ}C$ - $45^{\circ}C$ 内, 充电电池应没有永久损害。

Standard Discharge (标准放电)

Cells shall be discharged at a constant current of 0.2 C to 3.0 volts at $20^{\circ}C \pm 5^{\circ}C$.

电池以 0.2 C 恒流放电至 3.0V, $20^{\circ}C \pm 5^{\circ}C$ 。

If no otherwise specified, the rest time between Charge and Discharge amount to 30min.

如果没有特别说明, 电池充放电间隔时间为 30 分钟。



ShenZhen Fest Technology Co.,ltd

Baoshan Industrial Park, Longhua, Bao'an, Shenzhen, 518113,China

www.efestpower.com TEL:0755-89304183 FAX: 0755-27764602

Appearance (外观)

There shall be no such defect as flaw, crack, rust, leakage, which may adversely affect commercial value of battery.

电池外观应没有划痕、破裂、污迹、生锈、漏液等影响市场的缺陷存在。

Initial Performance Test (初始性能测试)

Table 2 (表 2)

Item (项目)	Test Method Condition (测试方法及条件)	Requirements (要求)
(1) Open-circuit Voltage (开路电压)	The open-circuit voltage shall be measured within 24 hours after standard charge. (标准充电后 24 小时内测量开路电压)	
(2) Internal impedance (初始内阻)	measured at AC 1KHz after 50% charged. (半充电状态下, 测量其 AC 1KHz 下的交流阻抗)	
(3) Minimal Rated Capacity (最小额定容量)	The capacity on 0.2 C discharge till the voltage tapered to 2.5V shall be measured after finish standard charge and rested for 30min. (标准充电后, 搁置 30 分钟, 测量 0.2 C 放电至 2.5V 截止电压所放出的容量)	Discharge Capacity (放电容量)

Temperature Dependence of discharge capacity (放电温度特性)

Cells shall be standard charged and discharged at 0.2 C to 3.0 volts. Except to be discharged at temperatures per Table 3. Cells shall be stored for 3 hours at the test temperature prior to discharging and then shall be discharged at the test temperature. The capacity of a cell at each temperature shall be compared to the capacity achieved at 23°C and the percentage shall be calculated. Each cell shall meet or exceed the requirements of Table 3.

电池按标准充电。按表 3 的温度中放电, 电池必须先在该试验温度中放置 3 个小时。在每一个温度中的放电容量应不小于表 3 的要求。

Table 3 (表 3)

Discharge Temperature (放电温度)	-10°C	0°C	23°C	60°C
Discharge Capacity(0.2 C) (放电容量/0.2 C)	70%	80%	100%	95%



Cycle Life and Date (循环寿命以及倍率)

Table 4 (表 4)

No. (序号)	Item (项目)	Criteria (标准)	Test Conditions (测试条件)
1	Cycle Life (循环寿命) (0.5 C)	Higher than 80% of the Initial Capacities of the Cells (初始容量的 80%)	Carry out 300 cycle Charging/Discharging in the below condition. <ul style="list-style-type: none"> ◆ Charge:Standard ◆ Discharge:0.5 Cto 2.5V ◆ Rest Time between charge/discharge:30min. ◆ Temperayure:20±5℃ 循环 300 次 充放电按以下条件: <ul style="list-style-type: none"> ◆ 充电: 标准充电, ◆ 放电: 0.5C 放至 2.5V ◆ 搁置: 30min ◆ 温度: 20±5℃
2	Leakage-Proof (漏液试验)	No leakage (visual inspection) (没有漏液/目测)	After full charged with standard charge, store at -20~60℃, 60±10%RH for 1 month. 标准充电条件下, 充满电后在温度-20~60℃,湿度 60±10%RH 下储存一个月

4. Mechanical characteristics and Safety Test (安全测试及机械特性)

Table5 (表 5) (Mechanical characteristics)

No. (序号)	Item (项目)	Test Method and Condition (测试方法及条件)	Criteria (标准)
1	Vibration Test 振动测试	After standard charging, fixed the cell to vibration table and subjection cycling that the frequency is to be varied at the rate of 1Hz per minute between 10Hz an 55Hz,the excursion of the vibration is 1.6mm.The cell shall be vibrated for 30minutes per axis of XYZ axes. 将标准充电后的电池固定在振动台上, 沿 X、Y、Z 三个方向各振动 30 分钟, 振幅 1.6mm, 振动频率为 10Hz~55Hz, 每分钟变化 1Hz。	No leakage 无泄漏 No fire 不起火
2	Drop Test 跌落测试	The cell is to be dropped from a height of 1 meter twice onto concrete ground. 将标准充电后的电池从 1 米高度跌落至混凝土地面 2 次	No explosion, No fire, 无爆炸、 无起火、



Table 6 (表 6)

(Safety Test)

Item (项目)	Battery Condition (电池要求)	Test Method (测试方法)	Requirements (要求)
Crush (挤压试验)	Fresh,Fully charged (充满电的新电池)	Crush between two flat plates. Applied force is about 13kN(1.72Mpa) for 30min. (电池放置在两块平面金属板间, 施加 13KN (1.72Mpa) 的作用力, 且持续保持 30 分钟)	No explosion,No fire (无爆炸, 无起火)
Short Circuit (短路试验 20°C)	Fresh,Fully charged (充满电的新电池)	Each test sample battery,in turn,is to be short-circuited by conneting the (+)and (-) terminals of the battery with a Cu wire having a maximum resistance load of 0.1Ω. Test are to be conducted at room temperature (20°C±2°C). (在常温下约 20±2°C, 依次把每个样品电池正负极用铜线连接起来, 是电池外部短路, 线路总电阻不超过 0.1Ω)	No explosion,No fire.The Temperature of the surface of the Cells are lower than 150°C (无起火, 无爆炸, 电池表面温度应低于 150°C)
Short Circuit (短路试验 60°C)	Fresh,Fully charged (充满电的新电池)	Each test sample battery,in turn,is to be short-circuited by connecting the (+)and (-) terminals of the battery with a Cu wire having a maximum resistance load of 0.1Ω. Test are to be conducted at temperature (60°C±2°C). (在温度约 60±2°C 下, 依次把每个样品电池正负极用铜线连接起来, 是电池外部短路, 线路总电阻不超过 0.1Ω)	No explosion,No fire.The Temperature of the surface of the Cells are lower than 150°C (无起火, 无爆炸, 电池表面温度应低于 150°C)
Impact (冲击试验)	Fresh,Fully charged (充满电的新电池)	A 56mm diameter bar is inlaid into the bottom of a 10Kg weight.And the weight is to be dropped from a height of 1m onto a sample battery and then the bar will be across the center of the sample.(用一条直径为 56mm 的圆棒放置在电池中央, 将一 10 公斤的重锤从 1 米的高度垂直落下在电池的中心位置)	No explosion,No fire (无起火, 无爆炸)
Forced Discharge (过放试验)	Fresh,Fully charged (充满电的新电池)	At 23±5°C, According to the requirements of standard charge, the cells will be discharge to cut-off voltage, then connect with external load of 30 ohm for 24 hours. 在 23±5°C 状态下, 按标准放电的要求放电至终止电压后, 外接 30Ω 负载放电 24 小时.	No explosion,No fire (无起火, 无爆炸)



5. Protection circuit (保护电路)

PCM Specification (保护板说明)

Item (项目)	Test Condition (测试条件)
Over charge Protection (过充电保护)	At $23 \pm 5^\circ\text{C}$, charging cells with constant current 3C to voltage 5.0V, then with constant voltage 5.0V till current decline to 0. Stop test till cells temperature 10°C lower than max temperature. 在 $23 \pm 5^\circ\text{C}$ 状态下, 电池用 3C 电流充电至 5.0V, 然后恒压 5.0V 让电流下降接近为 0A, 监视电池温度变化, 当电池温度下降一峰值低约 10°C 时, 停止实验.
Overs discharge Protection (过放电保护)	The battery should be discharged with 1C, The discharging should be shut off when the internal cell voltage becomes less than the specified protection voltage. (电池在 1C 的电流下放电, 当电池电压低于指定保护电压时, 放电就会停止)
Short protection (短路保护)	After rated charge, (+) and (-) terminals are connected with $10\text{m}\Omega$ mental resistor or equivalence. (额定充电后, 用 $10\text{m}\Omega$ 的电阻器连接电池的正负极, 电池符合标准要求)

6. Handling of Cells (电池操作注意事项)

Prohibition short circuit (禁止电池短路)

To avoid the cell short circuit. It generates very high current which causes heating of the cells and may cause electrolyte leakage are very dangerous. The Li-Fe tabs may be easily short-circuited by putting them on conductive surface. Such outer short circuit may lead to heat generation and damage of the cell. An appropriate circuitry with PCM shall be employed to protect accidental short circuit of the battery pack.

避免电池短路。短路会产生很高的电流而使电池发热以及电解液泄漏, 产生有毒气体使非常危险的。极片连接在导电物体表面很容易短路, 外部短路会导致发热及损害电池。选用一个适当的保护电路可以在意外短路时保护电池。

7. Notice for Designing Battery Pack (电池外壳设计注意事项)

7.1 Pack toughness (外壳坚韧度)

Battery pack should have sufficient strength and the Li-Fe cell inside should be protected from mechanical shocking.

电池外壳应该有足够的机械强度, 使铁锂电池免受机械撞击。

7.2 Cell fixing (电池的固定)

The Li-Fe cell should be fixed to the battery pack by its large surface area.

No cell movement in the battery pack should be allowed.

电池最大面积的一面应该固定在外壳上, 安装后电池不能有松动。

7.3 Inside design (外壳内部设计)

No sharp edge components should be insides the pack containing the Li-Fe cell.

外壳内安装电池的部位不应有锋锐边。



7.4 Tab connection (极片连接)

Spot welding is recommended for Li-Fe tab connection method.

Battery pack should be designed that shear force are not applied to the Li-Fe tabs.

If apply manual solder met hod to connect tab with PCM,below notice is very important to ensure battery

- ◆ • performance:
- ◆ • The solder iron should be temperature controlled and ESD safe;
- ◆ • Soldering temperature should not exceed 350°C;
- ◆ • Soldering time should not be longer than 3s;
- ◆ • Soldering times should not exceed 5 times,Keep battery tab cold down before next time soldrictly g;
- ◆ • Directly heat cell body is strictly prohibited,Battery may damaged by heat above approx.100°C.

建议使用点焊焊接方法：外壳设计应考虑使极片不受外力。

如果使用人工焊接保护板，下面的注意事项对于确保电池性能非常重要：

- ◆ • 焊接烙铁的温度必须可控且可防静电；
- ◆ • 焊接时对烙铁的温度不能超过 350°C；
- ◆ • 焊锡时间不能超过 3 秒钟；
- ◆ • 焊锡次数不能超过 5 次，待极片冷却后才能进行下一次焊锡；
- ◆ • 严禁直接加热电池，高于 100°C 会损害电池。

7.5 For mishaps (针对意外事件)

Battery pack should be designed not to generate heat even when leakage occurs due to mishaps.

- 1) Isolate PCM (Protection Circuit Module) from leaked electrolyte as perfectly as possible.
- 2) Avoid narrow spacing between bare circuit patterns with different voltage.(Including around connector)
- 3) Li-Fe battery should not have liquid from electrolyte,but in case if leaked electrolyte as possible touch bare circuit patterns,higher potential terminal material may dissolve and precipitate at the lower potential terminal,and may cause short circuit,The design of the PCM must have this covered.

发生意外时，外壳设计应考虑即使在电池出线漏液时也不会发热。

- 1) 尽量把保护电路与渗透的电解液隔离开。
- 2) 在不同的电压情况下避免出现小间距的裸露电路—包括插头的周围。
- 3) 锂电池不应该有来自电解液的液体，但是一旦发生电解液渗透触及裸露电路，高电势端接子材料可能会溶解然后沉淀到低电势端接子，可能会造成短路。保护板的设计须含有覆盖保护层。

8. Notice for Assembling Battery Pack (电池装配注意事项)

Shocks, high temperature, or contacts of sharp edge components should not be allowed in battery pack assembling process.

在电池装配过程中不允许撞击、高温或接触尖锐部分。

9. Others (其它)

9.1 Cell connection (电池连接)

- 1) Direct soldering of wire leads or devices to the cell is strictly prohibited.
- 2) Lead tabs with pre-soldering may cause damage of components, such as separator and insulator.by heat generation.

- 1) 严禁直接焊接引线或设备到电池上。
- 2) 极片在焊接引线之前应该先点焊到电池上，直接与电池热焊接，产生的热量会使电池的隔离体及绝缘体受损。



ShenZhen Fest Technology Co.,ltd

Baoshan Industrial Park, Longhua, Bao'an, Shenzhen, 518113,China

www.efestpower.com TEL:0755-89304183 FAX: 0755-27764602

9.2 Prevention of short circuit within a battery pack (电池内部的短路预防)

Enough insulation layers between wiring and the cells shall be used to maintain extra safety protection.

The battery pack shall be structured with no short circuit within the battery pack ,which may cause generation of smoke or firing.

在电池和引线之间应该有足够的绝缘层用于安全保护。电池的包装构成应没有导致起烟起火的短路情况。

9.3 Prohibition of disassembly (禁止拆卸)

1) Never disassemble the cells

The disassembling may generate internal short circuit in the cell,which may cause gassing,firing,explosion,or other problems.

2) Electrolyte is harmful

Li-Fe battery should not have liquid from electrolyte flowing,but in case the electrolyte come into contace with the skin,or eyes,physicians shall slush the electrolyte immediately with fresh water and medical advice is to be sought.

1) 不要拆卸电池。

拆卸电池会发生电池内部短路，会引起起火、爆炸、有害气体或其它问题。

2) 电解液是有害的。

9.4 Prohibition of dumping of cells into fire (不要把电池倾倒入火中)

Never incinerate nor dispose the cells in fire.These may cause explosion of the cells,which is very dangerous and is prohibition.

不要把电池扔入火中，容易引起爆炸。

9.5 Battery cells replacement (更换电池)

The battery replacement shall be done only by either cells supplier or device supplier and never be done by the user.

更换电池应由电池生产商或设备供应商完成，用户不用自行更换。

9.6 Prohibition of use of damaged cells (禁止使用损坏的电池)

The cells might be damaged during shipping by shock. If any abnormal features of the cells are found such as damages in a plastic envelop of the cell,deformation of the cell package,smelling of an electrolyte ,an electrolyte leakage and others,the cells shall never be used any more.

The cells with a smell of the electrolyte or a leakage shall be placed away from fire to avoid firing or explosion.

电池可能在出货途中碰撞而受损。如果发现电池有异常，例如包装损坏、包装包裹变形，有电解液的味道、发现漏液等等，不要再使用这些电池如果有电解液的味道或出现漏液，电池放置应该远离火源避免起火爆炸。

10. Period of Warranty (保质期)

The period of warranty is half a year from the date of shipment. Efest guarantees to give a replacement in case of cells with defects proven due to manufacturing process instead of the customer abuse and misuse.

电池的保质期从出货之日算起为半年。如果证明电池的缺陷是在制造过程中形成的而不是由于用户滥用及错误使用造成，本公司负责退换电池。



ShenZhen Fest Technology Co.,ltd

Baoshan Industrial Park, Longhua, Bao'an, Shenzhen, 518113,China

www.efestpower.com TEL:0755-89304183 FAX: 0755-27764602

11. Storing the Batteries (电池的存放)

The batteries should be stored at room temperature, charged to about 30% to 50% of capacity.

We recommend that batteries be charged about once per half a year to prevent over discharge.

电池应当在温室下存放，应充到 30%至 50%的电量。如长时间储存，建议每半年充一次电，以防止电池过放电。

12. Other The Chemical Reaction (其它的化学反应)

Because batteries utilize a chemical reaction, battery performance over time even if stored for a long period of time without being used. In addition,if the various usage conditions such as charge, ambient temperature, etc. are not maintained within the specified ranges the life expectancy of the battery may be shortened or the device in which the battery is used may be damaged by electrolyte leakage. if the batteries cannot maintain a charge for long periods of time, even when they are charged correctly,this may indicate it is time to change the battery.

由于电池是利用化学反应的原理，所以随时间的增加电池的性能会降低，即使是存放很长一段时间而不使用。如果使用条件如充电、放电及周围环境温度等情形不在指定的使用范围内，会缩短电池的使用寿命，或者会产生漏液导致设备损坏。如果电池长时间不能充电，即使充电方法正确，就要更换电池了。